

**Dual Channel High Resolution
VGA or DVI Graphics,
RGB/DVI/NTSC/PAL/STANAG A-C Input.
and Front and Rear I/O including PIM**

Support for Windows ■ Linux

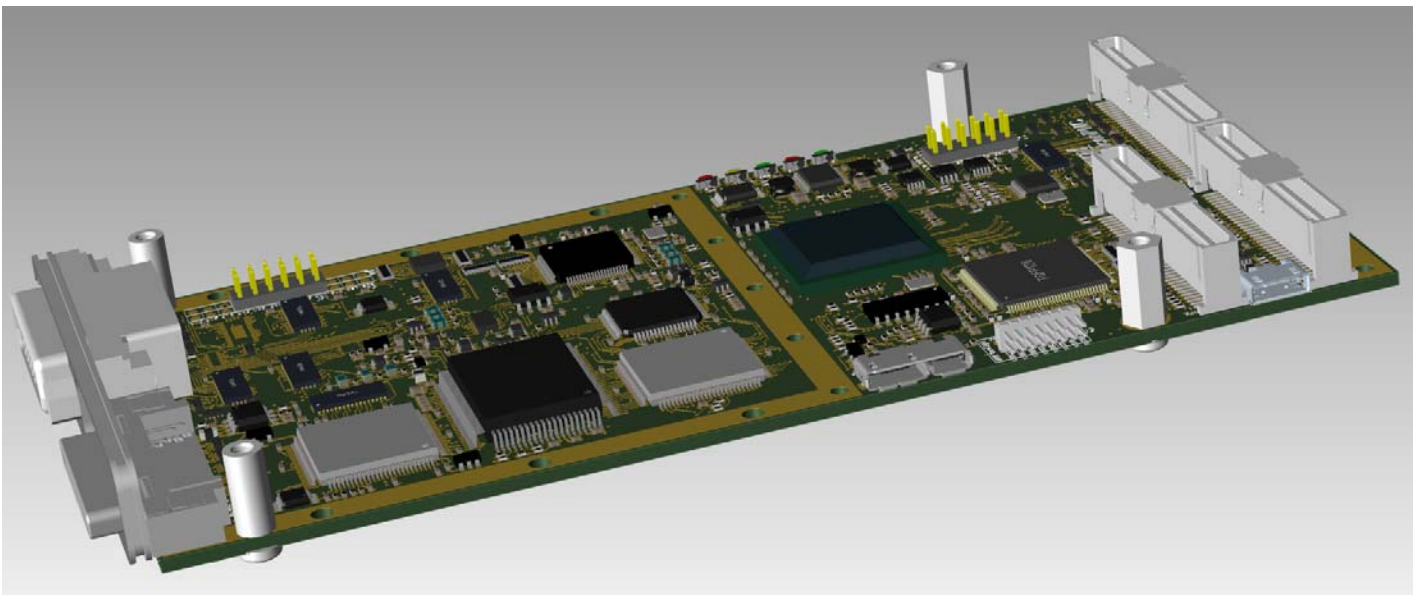

Features

- SM768 128-bit System On Chip graphics accelerator
- 256MB DDR3 display memory
- Supports two displays at up to 1920x1080
- Dual channel VGA or DVI
- NTSC/PAL/RGB/DVI/STANAG A-C capture
- Front panel and/or rear-panel (Pn4) connections
- PIM adapter available for rear-panel (Pn4) connections
- Windows XP-10, Linux, and VxWorks (5.x only)
- Companion to FalconXMC (XMC) version

Figure 1: FalconPMC Block Diagram

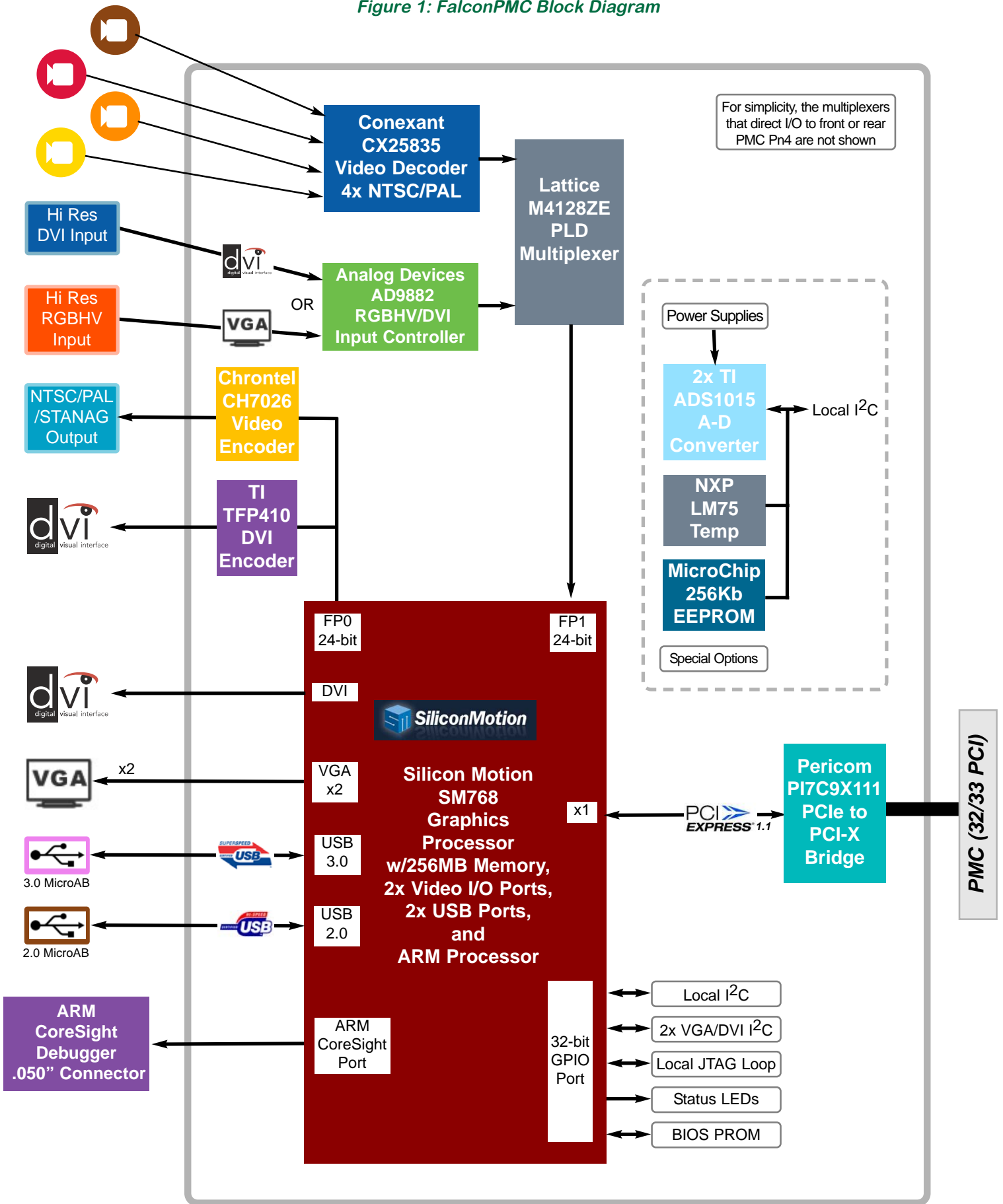

FalconPMC

Rastergraf's FalconPMC is a display controller and video capture PMC (PCI Mezzanine Card) board. The card is available with software for several operating environments (see page 10).

The FalconPMC is available in both display-only (FalconPMC/1x) and display/capture (FalconPMC/2) versions. The FalconPMC replaces the earlier TopazPMC products. Please refer to page 7 for more information.

FalconPMC features a Silicon Motion SM768 System On Chip (SOC) graphics accelerator with 256MB of on-chip DDR3 display memory. This 128-bit 2D graphics engine supports up to two compatible displays at up to 1920x1080. Outputs can be RGBHV (VGA), or DVI.

Optional features include a Conexant CX25835 NTSC/PAL/S-Video decoder, an Analog Devices AD9882A High Speed RGB/DVI digitizer, and a Chronitel CH7026 NTSC/PAL/STANAG encoder/scan-converter. A loopback can connect Video Output to Input for self-testing.

The FalconPMC front and rear I/O allocations are determined by the user-configured I/O Resource Matrix which maximizes I/O flexibility. Please refer to page 4 for a block diagram.

Built-In Self-Test (BIST) Option

All of Rastergraf's current generation graphics boards use an ARM uC to monitor board voltages and temperatures and determine viability of most critical ICs. In the case of the FalconPMC, the ARM uC that is incorporated into the SM768 graphics controller is used for this purpose. Status LEDs provide a quick indication of conditions. A special-order ARM development configuration provides 10-pin CoreSight ARM debugger port, USB 3.0 Micro AB, and I²C test connectors.

Embedded Life-Cycle Support

Rastergraf's comprehensive selection of PMC, XMC, CompactPCI, and PCI display and carrier solutions are designed to satisfy the product life-cycle requirements demanded by the embedded computing market.

The Embedded Graphics Source.

Rastergraf products include:

- Up to 6 head display/capture and capture-only boards for PMC and/or XMC
- CompactPCI, PCIe, and PCI carriers

Please contact Rastergraf for more information or consult our web page at www.rastergraf.com.

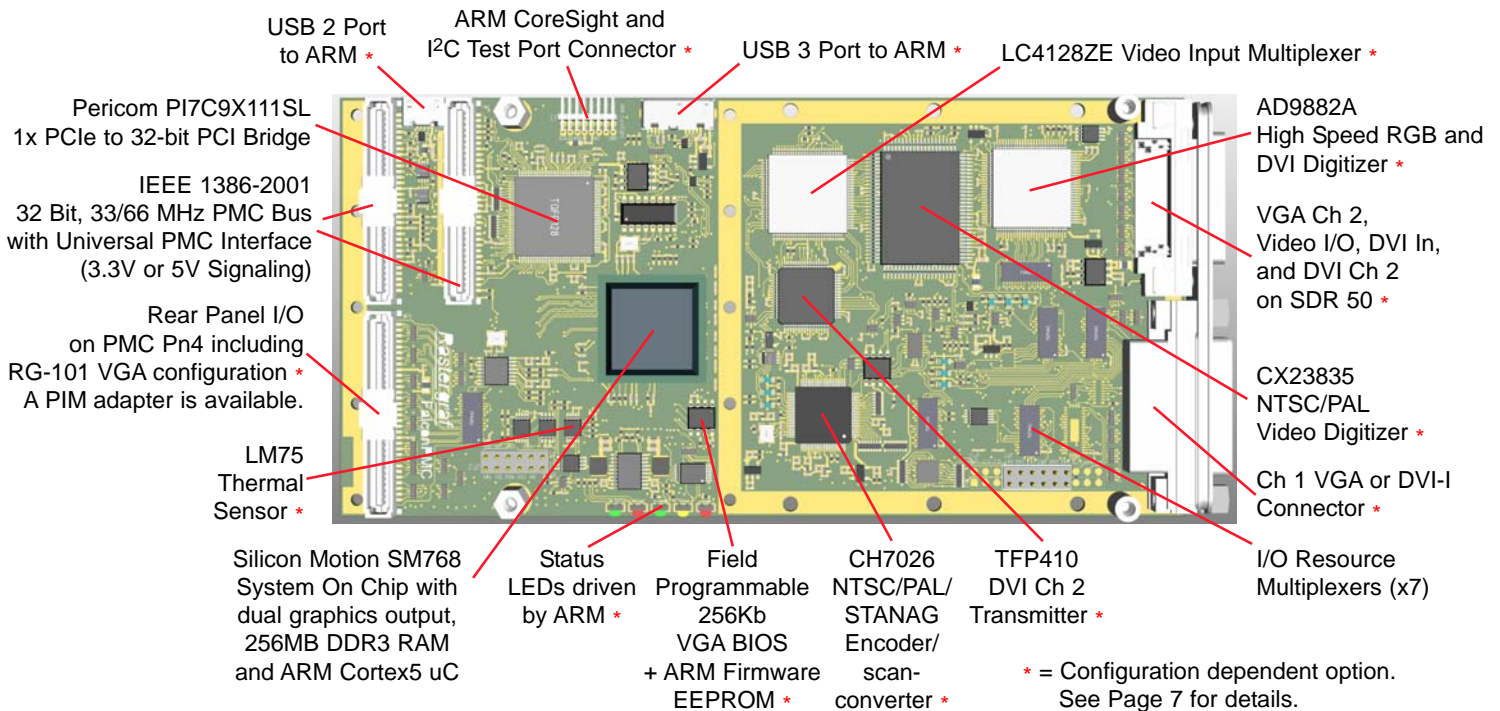

Features

- Silicon Motion SM768 dual display System On Chip
- 32-bit, 33/66 MHz PCI interface
- Pixel size is programmable for 8, 16, or 24 bits/pixel
- 256MB DDR3 Graphics Memory
- Display options include dual display VGA or DVI
- Hardware scroll, pan, and cursor
- VGA BIOS support
- Video Input Digitizer supports NTSC/PAL, STANAG 3350 A-C, and High Speed RGB or DVI input up to 1024 x 768
- Flexible assignment of front and rear panel connections
- RG-101 compatible RGBHV rear I/O version
- For use with PCI, cPCI, VPX, and VME hosts
- Windows XP-10, Linux (X, SDL), and VxWorks 5.x (only) SDL
- XMC version also available

FalconPMC Technical Overview

Introduction

The FalconPMC contains three major functional blocks: the Silicon Motion SM768 graphics System On Chip, the multimode video digitizers and encoders, and the I/O Resource Matrix (IORM).

System On a Chip Graphics Accelerator

The FalconPMC is powered by a Silicon Motion SM768 SOC graphics accelerator. It includes x2 PCIe 2.0, a single channel DVI encoder, two 24-bit I/O ports, dual 350 MHz VGA outputs, DMA controller, and ARM Cortex M5 microprocessor. The SM768 includes 256 MB DDR3 display memory with sufficient bandwidth to concurrently support large displays and other graphics and video processing functions.

Because the FalconPMC is a PMC board, the SM768's PCIe interface is necessarily coupled to the PMC connectors via a Pericom P703X111SL x1 PCIe 1.1 to 32-bit PCI bridge. While not ideal, there are no x1 or x2 PCIe 2.0-PCI bridges available and 64-bit PMC host positions are very rare now.

This x1 PCIe 1.1 bridge cannot use the full bandwidth of the SM768 and it may compromise results in a heavily loaded application with high resolution displays and video input active at the same time. Testing will be done to evaluate this. Please contact Rastergraf for more information.

SM768's 128-bit high performance graphics engine provides hardware acceleration of Bitblt, Stretch Blt, Line Draw, and Polygon Fill. It includes front-end color space conversion and scaled back-end YUV color space conversion. The SM768's hardware video decoder supports H.264 MVC/AVS+, H.263, MPEG, JPEG, RealVideo, VC-1, & Theora.

It supports dual independent channels up to 4K UHD - 3840x2160 @ 30p or Full HD - 1920x1080 @ 60p. It has dual 8-bit DACs with pixel rate up to 350 MHz with resolution support from basic VGA (640x480) up to 4K UHD (3840x2160) and Windows Display Modes include Extended Desktop Single & Dual View, Clone, and Portrait/Landscape modes.

The SM768 ARM Cortex M5 microprocessor has access to all internal devices and has the ability to operate autonomously of the host system. For the Falcon, the primary application is to run Rastergraf's Built-In-Self-Test (BIST) platform that is used to monitor and report status of most on-board devices.

Optional I/O Features

The SM768's dual channel 24-bit outputs are used on the Falcon for options including a second DVI encoder, an NTSC/PAL/STANAG encoder, and input data from the Falcon's optional Video/RGB/DVI capture encoder.

A Conexant CX25835 Video Digitizer selects and decodes 1-of-4 NTSC/PAL composite video or 1-of-3 composite plus S-Video. The CX25835 provides 16-bit YUV on-the-fly scaled and clipped digitized video images to the SM768 input port.

An Analog Devices AD9882A dual mode digitizer supports high speed 24-bit RGB or DVI up to 1024x768. RGB input can accept with separate or Sync-On-Green. STANAG 3350 A-C, which are component RGB signals with timing based on RS-343, PAL, and NTSC, respectively, are also supported. The AD9882A can supply the SM768's 24-bit input port either with a full 24-bit RGB or legacy 5:6:5 RGB.

The FalconPMC uses an LC4128ZE PLD to route the data to the SM768 as required by the CX25835 and AD9882A digitizers. Data format can be 24-bit or 5:6:5 RGB, 8-bit monochrome (G or YUV), or YUV422.

Image data can be captured by the host CPU using the SM768 DMA to transfer captured data in graphics memory into host memory. A self-test feature can connect the Composite Video Output to a video input.

Video Encoder Support

Using the optional Chronitel CH7026 encoder/scan converter, it is possible to generate both NTSC and PAL, as well as STANAG 3350 B (PAL timing) and C (NTSC timing).

It appears that it should also be able to generate 3350 A but testing still has to be done to verify this. Please contact Rastergraf for more information.

I/O Resource Matrix

The I/O Resource Matrix (IORM) is a set of user-controllable high-speed analog multiplexers that direct the FalconPMC inputs and outputs to the SDR 50 and DVI front panel or the rear panel I/O (Pn4) connectors.

Software Support

Software includes Windows XP-10, Linux X and Rastergraf SDL, and SDL on VxWorks 5.x (only). Please contact Rastergraf for more information.

FalconPMC Functional Diagram

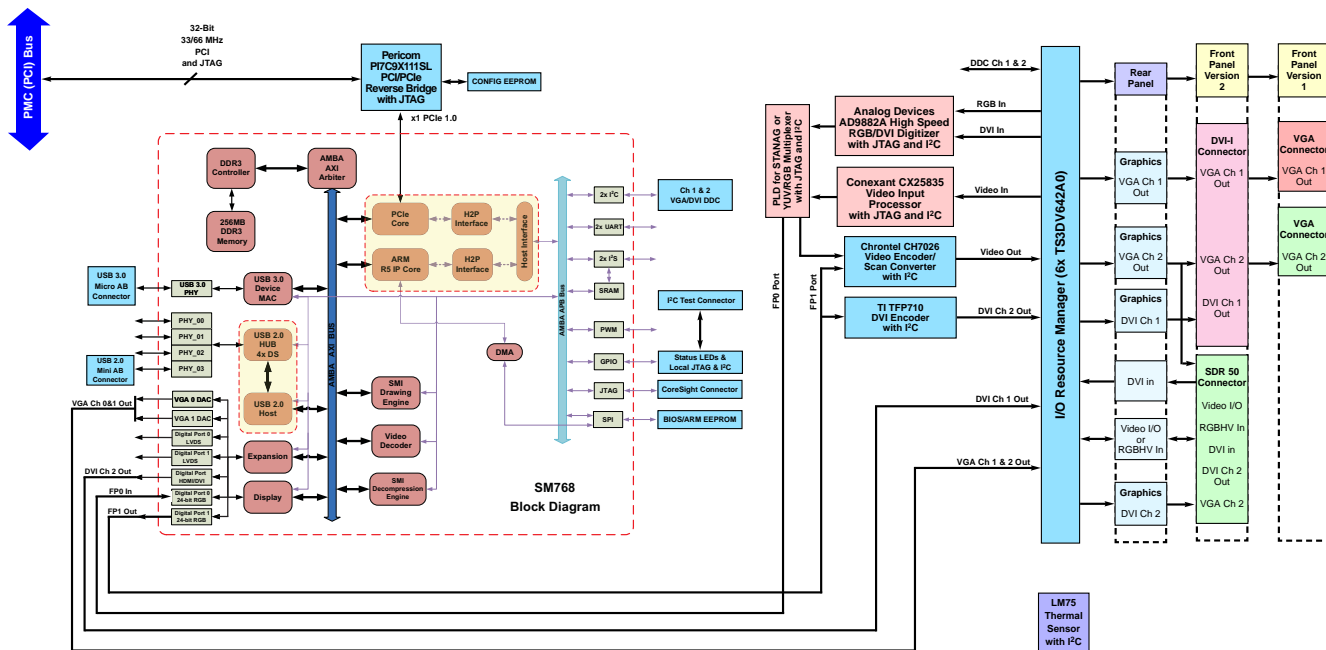

Display Formats and Output Usage

The FalconPMC is quite flexible in the way that the outputs can be set up. It has two independent timing generators (but only one drawing engine). The following table demonstrates

the breadth of outputs available. Please contact the factory if a special display mode is required.

Video Mode	Resolution	Pixel Size (bits)	Windows Format	Refresh Freq. (Hz)	Output Channel	Notes
Dual Analog Non-Interlaced	up to 1600x1200	8,16,32	UXGA max	60,75	VGA 1&2	
Dual Digital DVI	up to 1600x1200	8,16,32	UXGA max	60	DVI and SDR	
Analog Interlaced	RS-170 640x480	8,16,32		30	SDR	Uses CH7026 Encoder
Analog Interlaced	PAL 768x575	8,16,32		25	SDR	Uses CH7026 Encoder
Analog Interlaced	NTSC	8,16,32		30	SDR	Uses CH7026 Encoder
Analog Interlaced	S-Video (Y/C)	8,16,32		30	SDR	Uses CH7026 Encoder
STANAG 3350	Class A/B/C	8,16,32		30/25/30	SDR	Uses CH7026 Encoder

Video/RGB/DVI Input Capabilities

The FalconPMC has both low (CX25835) and high speed (AD9882A) digitizers. Together, they can digitize a wide range

of input signals. A loopback can connect the composite Video Output to Video Input 1 (on the CX25835) for self-testing.

Video Mode	Resolution	Pixel Size (bits)	Refresh Freq. (Hz)	Input Channel	Input Multiplexer	Sync On Green	Clip and Scale?	Notes
Analog Non-Interlaced (RGB)	up to 1024x768	16 or 24	60 max	AD9882A	no	optional	no	RGB = 565 or 888
Analog Interlaced (RGB)	STANAG 3350 A-C	16 or 24	30 max	AD9882A	no	yes	no	RGB = 565 or 888
Analog Interlaced (composite)	RS-170 640x480	16	30	CX25835	1 of 4	n/a	yes	YUV
	RS-343 875 Line	16	30	CX25835	1 of 4	n/a	yes	YUV
	PAL 768x575	16	25	CX25835	1 of 4	n/a	yes	YUV
	NTSC	16	30	CX25835	1 of 4	n/a	yes	YUV
	S-Video (Y/C)	16	25 or 30	CX25835	no	n/a	yes	YUV
Digital DVI	up to 1024x768	16 or 24	60 max	AD9882A	no	n/a	no	RGB = 565 or 888

FalconPMC Inputs and Outputs

Graphics Output Flexibility

FalconPMC supports a wide range of graphics configurations, directly supporting dual DVI or dual VGA outputs.

It should be noted that the FalconPMC can be configured in a number of different ways, and that the output sets described below are, in general, mutually exclusive.

Please feel free to contact Rastergraf if you have a special configuration in mind. The configuration table (below) necessarily cannot show all the valid combinations.

Analog Non-Interlaced Video Outputs

The FalconPMC can provide two analog display channels, each of which supports non-interlaced analog graphics. Outputs modes are dual VGA (RGBHV), and additionally for FalconPMC/2 boards, RGB with Sync-On-Green and RGB with separate composite sync.

DVI Outputs

The FalconPMC provides two single-link DVI outputs which use a four differential pair interface.

Video Output

The FalconPMC can be built with a Chromtel CH7026 encoder -scan-converter that can supply Composite/NTSC/PAL, component S-Video, or STANAG 3350 A-C output formats.

Video Inputs

The FalconPMC's SM768 graphics controller provides a 24-bit video input channel. In conjunction with the CX25835 NTSC/PAL decoder and AD9882A RGBHV/DVI decoder, it supports wide variety of video formats including a high-res input mode (up to 1024 x 768) DVI or RGBHV or a 1-of-4 composite (NTSC/PAL/SECAM) or single component (S-Video) input.

ESD Protection

ESD protection is provided for virtually all non-PMC I/O pins to protect the ICs on the Falcon.

I/O Configuration Matrix Block Diagram

Using user-programmable multiplexers, the I/O can be directed to the PMC P4 rear panel connector or the front panel connectors, which can be VGA, DVI+VGA, VGA+VGA, or DVI+SDR 50, depending on the application.

The diagram (below) illustrates the way the I/Os can be linked to the connectors.

Custom cables (see Page 9) are available from Rastergraf for

- a) DVI-I cable with DVI-D and VGA Ch 1&2 for /T version
- b) SDR 50 for DVI-I for Ch 2 DVI+VGA), DVI-D for DVI In, VGA for Video In or RGBHV In, and VGA for Encoded Video Out (NTSC/PAL/STANAG) or VGA (Ch 1 or 2).

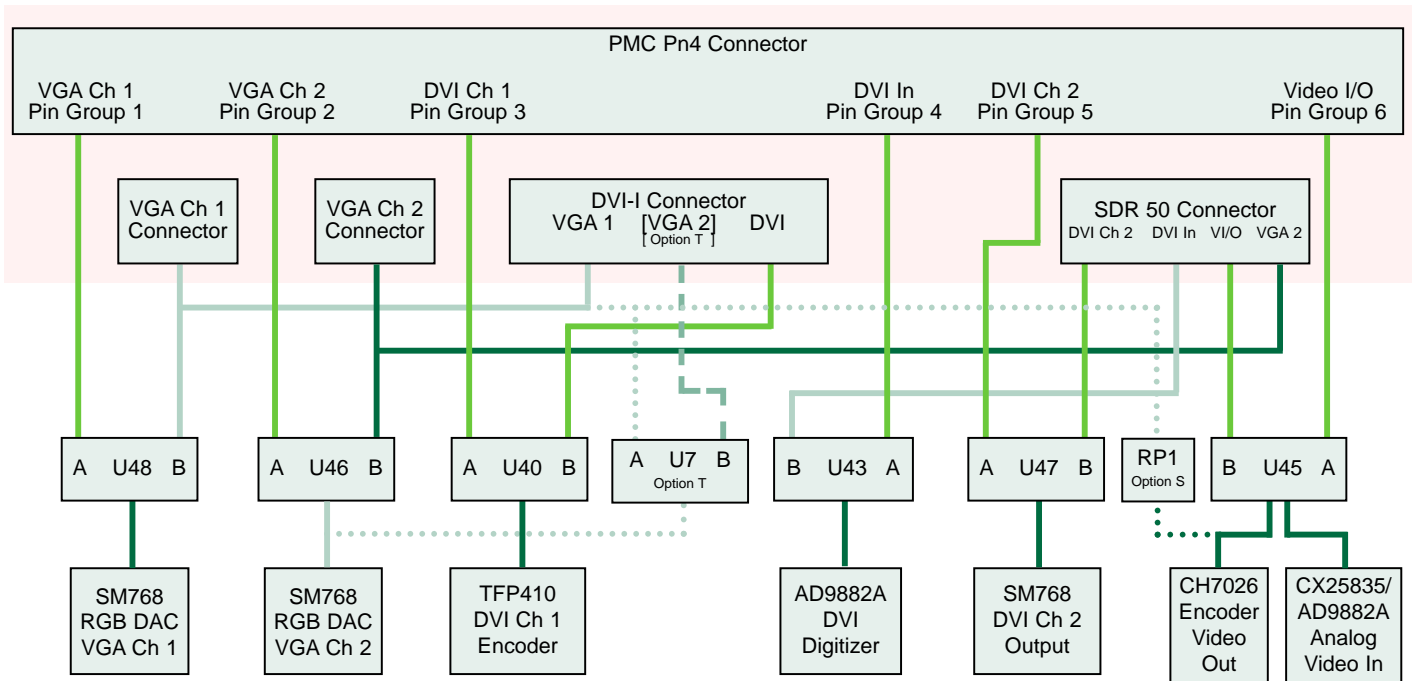

Front Panel Configurations

The following table shows the common front panel configurations. Due to the limited front panel space, special breakout cables are required to fully utilize the feature set of some Falcon configurations. This is noted in the table below.

Please consult the Pn4 Signal Set Availability chart (below) for more information about rear panel connectivity or contact Rastergraf for ordering assistance.

The User's Manual provides comprehensive information about connectors and cabling.

Special Order Versions (contact Rastergraf)

FalconPMC/1R Single front panel VGA and Pn4 (RG-101).

FalconPMC/1S Single front panel VGA with STANAG 3350 A-C.

FalconPMC/1T DVI-I with DVI and VGA Ch 2.

Falcon Version	Breakout Cable(s) (see page 9)	VGA Ch 1	VGA Ch 2	DVI Ch 1	DVI Ch 2	NTSC/ PAL/ STANAG Video I/O	DVI In	ARM Alive	Legacy Product Closest Equivalent (new s/w req'd)
FalconPMC/1V	Standard VGA cables	VGA 1	VGA 2					optional	TopazPMC/1V
FalconPMC/1D	Standard DVI-I cable SDR: A31-00737-1012	DVI-I	SDR 50	DVI-I	SDR 50			optional	
FalconPMC/2	Standard DVI-I cable SDR: A31-00737-1012 and A31-00739-1012	DVI-I	SDR 50	DVI-I	SDR 50	SDR 50	SDR 50	optional	TopazPMC/2A-C

Note 1: Any signal sets allocated to rear Pn4 connector will not be available for front panel access (or vice versa).

FalconPMC and FalconPIM Front Panels

Front Panel for
FalconPMC/1V

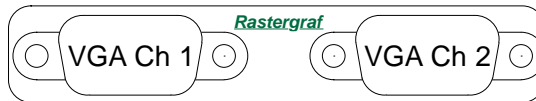

Front Panel for
FalconPMC/1D and
FalconPMC/2

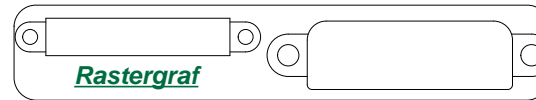

Pn4 Signal Set Availability

The FalconPMC PMC Pn4 connector can supply a variety of signal sets. The choices are controlled by user-programmable multiplexers on the FalconPMC.

When setting up the board, you have to choose between front connector(s) and Pn4 for each signal set. You cannot have the same signal set on both front and rear connectors at the same time.

The Pn4 connections are divided into 6 signal sets, or Pin Groups.

Please contact the factory if you have a special configuration requirement. Also, refer to the User's Manual, Section 2.6 and Chapter 3, which provide comprehensive information about connectors and cabling.

Pn4 Pin Group 1	Pn4 Pin Group 2	Pn4 Pin Group 3	Pn4 Pin Group 4	Pn4 Pin Group 5	Pn4 Pin Group 6
VGA Ch 1 (if not used on front)	VGA Ch 2 (if not used on front)	DVI Out Ch 1 (if not used on front)	DVI In (if not used on front)	DVI Out Ch 2 (if not used on front)	Video I/O (if not used on front)

FalconPIM

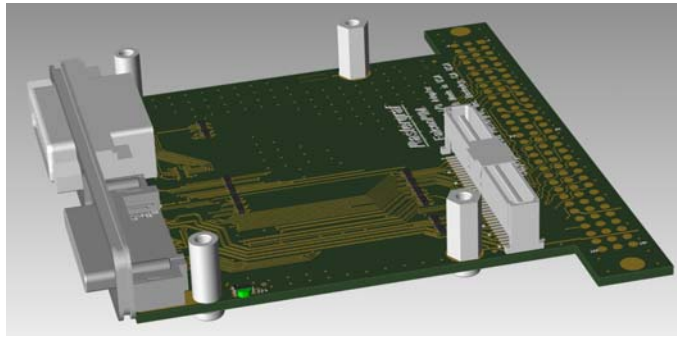

The FalconPIM provides convenient connector breakouts for rear panel (Pn4) applications. Due to the limited front panel space, special breakout cables are required to utilize some of the functions provided on some Falcon configurations. This is noted in the table below.

Please contact the factory if you have a special configuration requirement. Also, refer to the User's Manual, Section 2.6 and Chapter 3, which provide comprehensive information about connectors and cabling.

FalconPIM Version	Breakout Cable(s) (see page 9)	VGA Ch 1	VGA Ch 2	DVI Ch 1	DVI Ch 2	NTSC/ PAL/ STANAG Video In/Out	DVI In
FalconPIM/1V	Standard VGA cables	VGA 1	VGA 2				
FalconPIM/1D	Standard DVI-I cable SDR: A31-00737-1012	DVI-I	SDR 50	DVI-I	SDR 50		
FalconPIM/2	Standard DVI-I cable SDR: A31-00737-1012 and A31-00739-1012	DVI-I	SDR 50	DVI-I	SDR 50	SDR 50	SDR 50

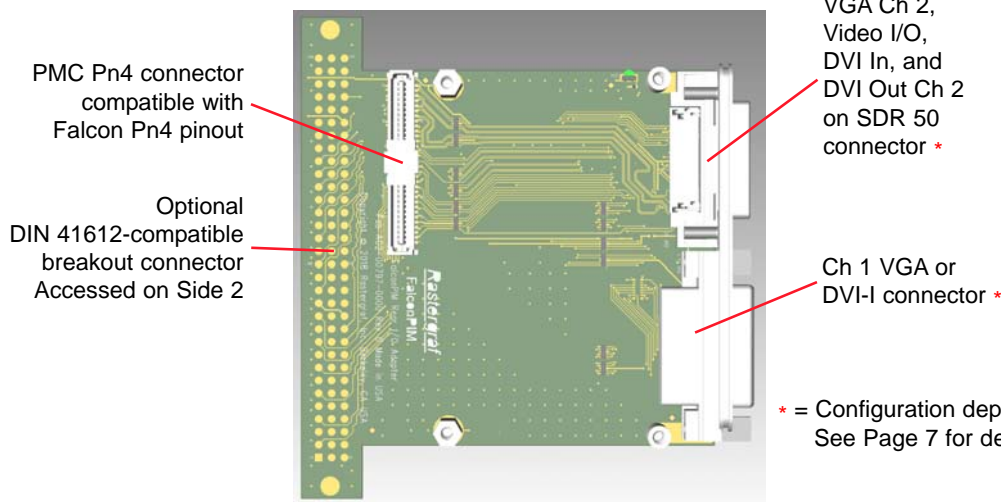

FalconPMC Special Cables

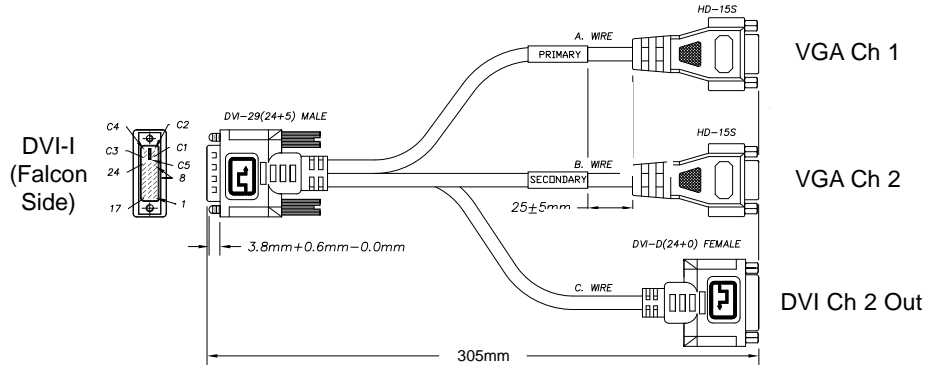

A31-00735-1012 (VLG-3/1) cable assembly for /T version

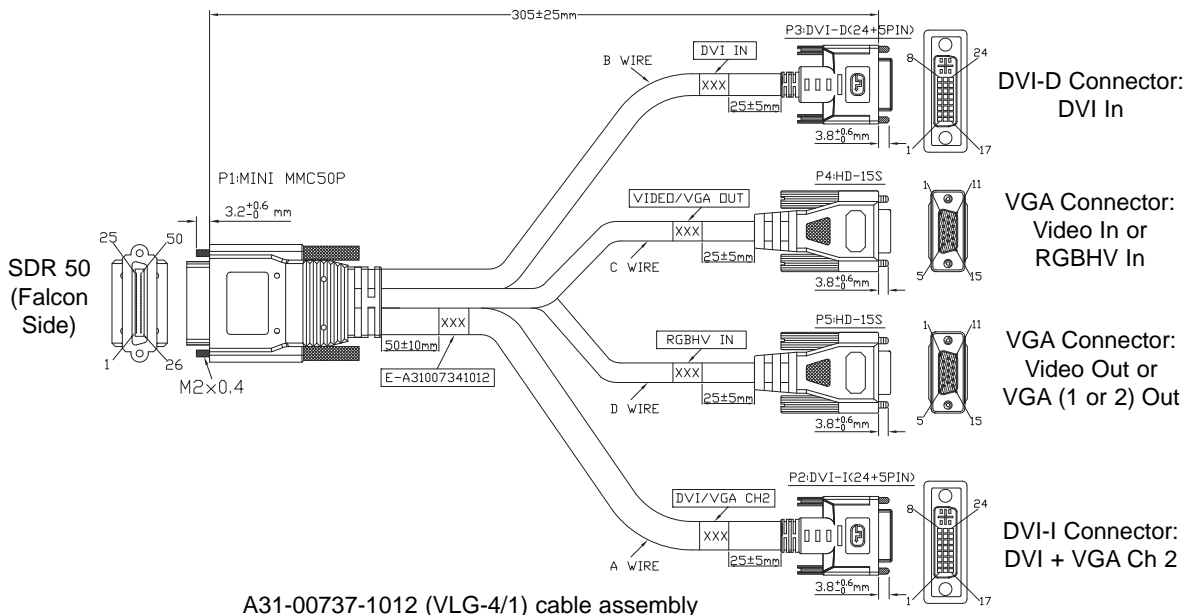

A31-00737-1012 (VLG-4/1) cable assembly

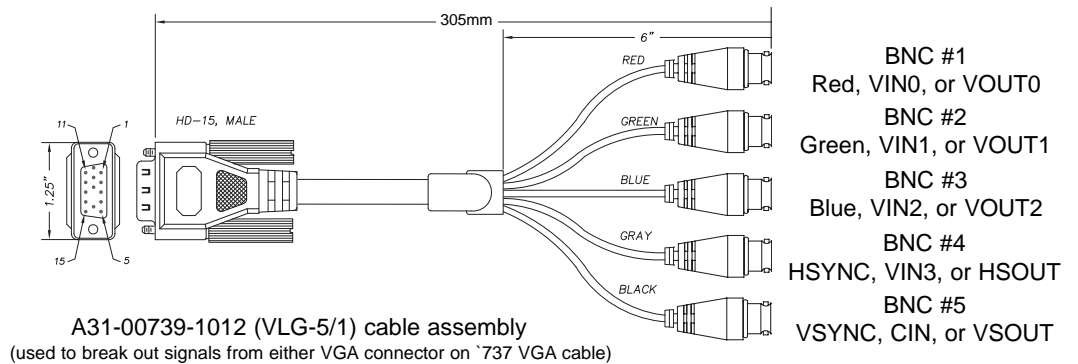





A31-00739-1012 (VLG-5/1) cable assembly
(used to break out signals from either VGA connector on '737 VGA cable)

- BNC #1
Red, VIN0, or VOUT0
- BNC #2
Green, VIN1, or VOUT1
- BNC #3
Blue, VIN2, or VOUT2
- BNC #4
HSYNC, VIN3, or HSOUT
- BNC #5
VSYNC, CIN, or VSOUT

Graphics Software Support

SDL Subroutine Library includes video capture and Built-In Self Test modules
 WindML support (requires SDL) including video input extensions
 Accelerated X Server with Xv video input extensions
 Windows 2K/XP drivers including accelerated DirectX

Software Support Matrix

	SDL		<i>Video Input</i>	<i>DirectX</i>
VxWorks 5.x x86/PowerPC	 ✓		✓	
Windows XP-10				✓
Linux x86/PowerPC	 ✓	✓	✓	

SDL Graphics Library

SDL is a graphics library designed to be a device-independent programming interface. SDL is ideally suited to demanding board level and embedded systems applications. Drivers are available for selected host CPU boards and operating systems. SDL is supplied in object library format, which means that its target code size can be controlled by limiting the number of functions used in a given application. SDL has been designed to run on any CPU and operating system that uses linear addressing and is supported by the GNU C compiler and linker.

SDL is easy to use. It includes a complete set of graphics primitives that interface to the SM768 graphics controller's accelerated functions. SDL also supports video capture capabilities. All graphics primitives are drawn as single pixel lines. Rectangles, polygons, circles, ellipses, and chords can be filled with a solid color or stipple patterns.

Complete information about SDL is contained in the Standard Drawing Library C Reference Manual that is available for download from our web site at <http://www.rastergraf.com>.

SDL Feature Summary

- Solid (thin and wide) and dashed lines, polylines, and rectangles
- Pixblits to/from the display and host memory
- Filled and hollow polygons, ellipses, circles, sectors, and chords
- Solid and Pattern Fills - Pixel Processing
- Proportional and Fixed Width Fonts
- Clipping Rectangle and Logical Origin
- VGA 640x480 to 1600x1200 (dual display)
- 8/16/24 bpp
- DVI Output (dual display)
- Sync On Green and Composite Separate Sync outputs (FalconPMC/2)
- Video Capture - NTSC/PAL, S-Video via CX25835
- Video Capture - high speed DVI, RGB, or monochrome via AD9882A
- TV/Video Out - NTSC/PAL/STANAG 3350 A-C

Ruggedization

Rastergraf is not in the militarized business. The intent of the following table is to illustrate how the Rastergraf graphic boards fit into the standard ruggedized classes.

Rastergraf boards use standard distribution grade derated commercial temperature range or industrial temperature range components. No formal component tracking is maintained.

Spec	Air-Cooled Level 0	Air-Cooled Level 50	Air-Cooled Level 100	Air-Cooled Level 200
Graphics Boards	AgatePXC FalconPMC MerlinPXC	AgatePXC FalconPMC MerlinPXC	FalconPMC MerlinPXC	FalconPMC
Operating Temperature (4, 6)	0°C to 50°C	-20°C to 65°C	-40°C to 71°C	-40°C to 85°C
Storage Temperature	-40°C to 85°C	-40°C to 85°C	-55°C to 125°C	-55°C to 125°C
Humidity Operating	0 to 95% non-condensing	0 to 100% non-condensing	0 to 100% non-condensing	0 to 100% non-condensing
Humidity Storage	0 to 95% condensing	0 to 100% condensing	0 to 100% condensing	0 to 100% condensing
Vibration Sine (1)	2 g peak 15-2 kHz	2 g peak 15-2 kHz	10 g peak 15-2 kHz	10 g peak 15-2 kHz
Vibration Random (2)	0.01 g ² /Hz 15-2 kHz	0.02 g ² /Hz 15-2 kHz	0.04 g ² /Hz 15-2 kHz	0.04 g ² /Hz 15-2 kHz
Shock (3)	20 g peak	20 g peak	30 g peak	30 g peak
Conformal Coat (5)	optional	optional	optional	optional
Ordering Option (7)	/CA or /CS	/A5A or /A5S	/A1A or /A1S	/A2A or /A2S

Notes:

1. Sine vibration based on a sine sweep duration of 10 minutes per axis in each of three mutually perpendicular axes. May be displacement limited from 15 to 44 Hz, depending on specific test equipment. **Shock and Vibration values are by design and not tested in production.**
2. Random vibration 60 minutes per axis, in each of three mutually perpendicular axes.
3. Three hits in each axis, both directions, 1/2 sine and saw tooth. Total 36 hits.
4. Standard air-flow is 8 cfm at sea level. Some higher-powered products may require additional airflow. Consult the factory for details.
5. Conformal coating type to be specified by customer. Consult the factory for details.
6. Temperature is measured at the card interior (not at edge) using on-board LM75 temperature monitor.
7. Last letter in ordering option: A for Acrylic Conformal Coating, S for Silicone Conformal Coating

Product Specifications

Graphics Controllers	Silicon Motion SM768
Maximum Dot Clock	300 MHz
Horizontal Scan Rates	31.5 to 115 kHz
Display Memory	256 MB DDR3 RAM
Display Colors	16.7 Million @ 24-bits, 256 @ 8-bits
Digitizers	Conexant CX25835 with 4 input mux and S-Video supports NTSC/PAL cameras Analog Devices AD9882A RGB/DVI supports RGBHV, RGB with Sync-On-Green or Composite Sync, STANAG 3350 A-C, or DVI inputs up to 1024x768. Output to SM768 is either 8:8:8 or 5:6:5 RGB or YUV.
Environment	Temperature: 0°C to +70°C, operating, -55°C to +85°C, storage Humidity: 5% - 95% non-condensing
Power Requirements	+3.3V ±5%, 1.3A +5V ±5%, 0.1A Measurements do not include 5V power sourced to Ch 1 & Ch 2 VGA/DVI (limited to 1A total).
Compatibility	IEEE 1386-2001, 32-bit, 66 MHz Universal PCI Bus signaling (5V and 3.3V)
PCI Device IDs and Interrupts	SM768 IDSEL = PMC IDSEL, INTA LM75 INTB
PCI Subsystem Vendor ID	0x10F0 (Vendor Code)
PCI Subsystem Device ID	0x00C7 (FalconPMC Identifier)
Dimensions	149 mm x 74 mm
Board I/O Connections	Controlled by the IO Resource Director
Front Panel	2x VGA or DVI-I & SDR 50
Rear (PMC Pn4)	64 pin PMC connector
Cautionary Note	DVI interface cabling require matched length signal sets. Other I/Os require signal+ground pairs.
I/O Resource Matrix (IORM) (user-configurable)	Connections can be be directed either to the front panel OR the PMC Pn4 rear I/O. DVI connector: 2 x VGA and DVI Ch 1 Out SDR 50 Connector: NTSC/PAL, Video I/O, HS RGBHV, DVI In, DVI Ch 2, VGA Ch 2 Rear (Pn4): NTSC/PAL, Video I/O, HS RGBHV, DVI In, DVI Ch 2, VGA Ch 1/2
Analog Monitor Support	Dual channel, VGA, non-interlaced (only), up to 1920x1080. Option to support Sync-On-Green or Composite Sync.
Composite Video Signal	1 Volt peak to peak, consisting of: 660 mV Reference White 54 mV Reference Black 286 mV Sync
DVI Digital Monitor Support	Dual channel, up to 1920x1080
VGA BIOS	Allows board to function as system console.
Maintenance Features	DDC-2B control enables system software to interrogate monitor for type and capabilities; LM75 thermal sensor can report board temp; composite video In/Out loopback; ARM CPU contained in SM768.
Power-management capabilities	Depending on operating system support, most devices can be at least partially powered down.

Ordering Information

FalconPMC General Description

Silicon Motion SM768 Graphics Accelerator, 256 MB DDR3, I/O Resource Director, and VGA BIOS.

- >> Display options for dual VGA out or dual DVI
- >> Options for Video I/O and/or DVI input.
- >> Option for single channel STANAG 3350 A-C output
- >> Options for front panel and/or PMC Pn4 connections.
- >> PIM adapter available for Pn4 cable breakouts.

FalconPMC/1V

Dual front panel VGA connectors

FalconPMC/1D

Front panel connectors are DVI-I and SDR 50 and supply 2x VGA and 2x DVI.

FalconPMC/2 version includes basic feature set plus

Conexant CX25835 video digitizer
Analog Devices AD9882A High Speed RGB/DVI Digitizer
Chrontel CH7026 NTSC/PAL video encoder
Support for RGB output with Sync-On-Green or Composite Sync
Display outputs include dual VGA and **single** DVI
Front panel connectors are DVI-I and SDR 50
Both DVI outputs are available on the Pn4 connector.
Breakout cable(s) required to access all functions (see below)

DVI-I and Pn4 connector signal assignments are made with user jumpers per the I/O Configuration Block Diagram on Page 6.

On /2 boards, a second DVI can be generated using an external VGA to DVI converter (see below, VGD-1) or accessed on Pn4.

FalconPIM/1V

Dual VGA connectors on PIM for use on a rear I/O PIM carrier

FalconPIM/2

DVI-I and VGA connectors on PIM for use on a rear I/O PIM carrier. User jumpers set signal assignment on connectors.

Options

VGD-1

VGA to DVI adapter

A31-00735-2012 (VLG-2/1)

DVI-I to DVI-D plus single VGA breakout cable, 1 ft.

A31-00735-1012 (VLG-3/1)

DVI-I to DVI-D plus dual VGA breakout cable, 1 ft.

A31-00737-1012 (VLG-4/1)

SDR 50 to DVI-I, DVI In, 2xVGA (for Encoder and Video In), 1 ft.

A31-00739-1012 (VLG-5/1)

VGA to 5 BNC, 1 ft.

Software:

SDL/RX.X

SDL graphics library for x86/PPC VxWorks 5.x or x86/PPC Linux.

Windows Drivers

Display, video input, and DirectX drivers for Windows XP-10.

DRV/LN/RX.X

Video Input and 2D accelerated X-Windows DDX drivers for x86/PPC Linux.

NOTE: /RX.X is software revision number, subject to change.

www.rastergraf.com

Rastergraf, Inc.

1810-J SE First Street
Redmond, Oregon 97756
tel: +1 (541) 923-5530
email: sales@rastergraf.com

Important Notices:

Trademarks are property of their respective owners.