



# Fusion™ 878A

PCI Video Decoder

Conexant's Fusion™ Family of PCI Video Decoders Integrates Broadcast Video and Data Capture, and Playback in a Single Chip

The newest addition to the Fusion family of PCI video decoders is the Fusion 878A. It is a multifunctional PCI device based on the original Bt878/879 products. The Fusion 878A is pin-for-pin compatible with the Bt878/879, and adds enhanced performance capabilities in video and broadcast communication services. Fusion 878A addresses the current analog TV requirements as well as the evolving digital TV broadcast standards like ATSC (American Television Standards Committee) and DVB (Digital Video Broadcast). The Fusion 878A is PC 98 and PC 99 compliant. Also, Fusion 878A conforms to the Advance Configuration Power Interface (ACPI) and power management requirements outlined in the PCI Bus Power Management Specification 1.0.

Fusion 878A integrates more of the external biasing circuitry, which reduces the overall bill of materials and improves performance characteristics of video and clocking. This enables customers to develop cost-effective, yet flexible solutions addressing analog and digital video.



## Distinguishing Features

- Supports NTSC/PAL/SECAM video input
- Worldwide graphics controller compatibility
- PC 98/99 compliant
- ACPI and power management
- Transport stream DMA for ATSC and DVB digital broadcast
  - 40 Mb/s serial I/O
  - 20 MB/s parallel I/O

# Fusion 878A

## PCI Video Decoder

### General Features

Because Fusion 878A is fully compatible with the current Bt878/879, upgrading to requirements like PC 98/99 compliance is a minimal investment. Also, customers can standardize with one PCI video decoder to enable multiple configurations of TV cards that address the broad spectrum of broadcast requirements around the world. Because Fusion 878A is based on the Bt878/879, customers can continue to support their products using one software code base, adding functionality by including additional software modules.

Features	Bt878	Fusion 878A
All Bt848A Features	X	X
Mono Audio	X	X
DVCR	X	X
PC 99 Compliance		X
ATSC Digital TV		X
DVB		X

### Transport Stream DMA for Digital Television

The analog and digital audio paths have been modified for increased bandwidth and functionality. The asynchronous parallel port, which uses the analog data path, has an increased raw data rate of 20 MB/s. Additionally, the I<sup>2</sup>S port has been modified to handle data up to 40 Mb/s. This added functionality makes Fusion the ideal choice for ATSC, DVB, DBS, and digital cable platforms on the PC.

Driver software is available to move transport packet streams from a wide variety of digital demodulators to host memory using the Fusion 878A DMA engine. Therefore, building next generation digital broadcast solutions on the proven Bt878 platform is easy and low risk since the software is incremental to existing Fusion software.

### PC 99 Compliance

#### ACPI and Power Management Interface

Fusion 878A supports ACPI and the Power Management Interface 1.0 specifications, making the Fusion 878A the product of choice for green PC and notebook applications.

### Vital Product Data

Vital Product Data (VPD) is required by PCI specification version 2.2. Through the Fusion 878A and the use of an external EEPROM, manufacturers can store information that identifies the product down to the serial number. The data is stored in ASCII format and is accessible through the configuration space VPD interface registers. This feature provides board manufacturers and PC OEMs the ability to more accurately track their product as well as offer improved or enhanced customer support.

### Worldwide Video Support

The Fusion family supports all the features and flexibility of the Bt848A video solution, including the integration of a NTSC/PAL/SECAM composite and S-video decoder, high-quality scaler, and PCI bus



master on a single device. Like the Bt848A, the Fusion family can place video data directly into host memory for video capture applications and into a target video display frame buffer for video overlay applications.

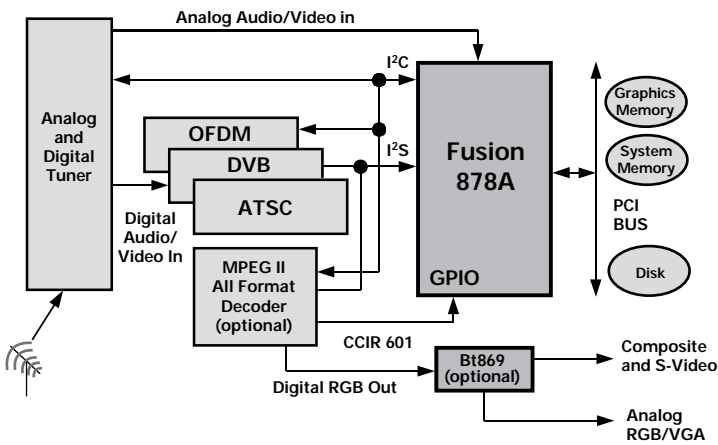

Digital television receiver for the PC

## Fusion Software Drivers

Fusion offers a suite of widely fielded software drivers for Windows 95 and Windows 98. With the VxD drivers, board developers can support products using either the Windows 95 or Windows 98 operating systems. VxD and WDM drivers provide video capture, playback and display in accordance with Microsoft's Video for Windows and Direct Show 2.0, respectively. Dialog boxes, tuner, GPIO, and I<sup>2</sup>C modules can be modified and customized by board developers.

Fusion software drivers are supported by the industry's broadest base of ISV applications commercially available for video editing, teleconferencing, compression, television on the PC and video email. Software is available through retail and OEM channels.

## What is a PCI Video Decoder?

A PCI bus analog video decoder is used for three primary PC solutions: video capture and editing, video teleconferencing, and television receiver cards. A video signal is generated by a video source, which can be a camera, VCR or TV tuner. The baseband video that goes into the PCI decoder is a simple analog signal that contains video analog data and video synchronization data, which is used to display the picture properly at the receiving end. The details of the signal depend on the video standard used — NTSC (National Television Standards Committee), PAL (Phase Alternate Line) or SECAM (Systeme Electronique Couleur Avec Memoire). To transmit the picture, the source generates a vertical synchronization signal (VSYNC). This signal resets the receiver (PC monitor) so that it begins picture display at the top of the screen. After the VSYNC signal is sent, the video source scans the first line of the image. Once the scan line is complete, the camera generates a horizontal synchronization signal (HSYNC), which resets the receiver so that it will display the next line starting at the left-hand edge of the display. For each line of the image, a scan line and a horizontal synchronization pulse are sent. The PCI bus attached to the video decoder is the access mechanism, or hub, for this video information traveling to the PC. The need for broadcast data in the PC is a primary reason analog dedicated PC television receiver cards are becoming very popular. The introduction of WebTV for Windows and national broadcaster support of Vertical Blanking Interval (VBI) content contribute to addressing the need for a feature rich, broadcast data function in the PC. PCI video decoder solutions provide the most effective means to achieve this.

## Ultralock™ and Scaling Support

Fusion 878A, like the Bt848A, Bt878, and Bt879, utilizes Conexant's patented Ultralock technology that locks to an incoming analog video signal. Ultralock is able to recognize unstable video signals caused by VCR headswitches or any other video source, and adapt the locking mechanism to accommodate the source.

Fusion is able to scale the video image size both vertically and horizontally, using arbitrarily selected scaling ratios. The X and Y dimensions can be scaled to one-sixteenth of full resolution. Vertical scaling is implemented with Conexant's industry leading 5-tap vertical filter.

## Byte Alignment

Byte alignment is used to improve video performance in packed color modes. Often, video applications are written around the planar, not the packed color mode of operation. The result is video which is not DWORD aligned. To the end-user, the color of the video appears misrepresented, showing more R, G, or B (Red, Green, or Blue) than is actually there. Fusion compensates for non-DWORD aligned data by aligning each DWORD with the correct byte lanes in the targeted address.

## Fusion 878A

### Distinguishing Features

- Supports multi-standard NTSC/PAL/SECAM video decoding
- Two DMA channels for simultaneous transmission of digital video and/or HDTV/ audio/MPEG2 transport data across PCI bus
- Supports downstream HDTV transport data via DMA at rates of 40 Mb/s. In serial mode and 20 MB/s in parallel mode
- Can interface to VSB or OFDM demodulators
- Selectable pixel density available - 8, 16, 24, and 32-bits per pixel
- Supports planar YUV, YCrCb, RGB pixel data formats
- Supports complex clipping of video source and VGA video overlay if needed
- Executes Windows '98 'Scatter and Gather'
- 4 composite and 1 S-Video inputs concurrently
- Chroma and luma comb filters/scalers
- Horizontal scaling and vertical cropping
- Filters and scales Y/C video with a 6-tap luma/2-tap chroma polyphase circuit block
- VBI data capture circuitry and software for closed captioning and teletext
- Accepts mono line level and MIC audio signals
- Supports Microsoft's Direct Sound API

- Performs audio capture without additional analog audio cable to sound card
- PCI Rev. 2.2 Compliant
- WHQL-certifiable
- Packaged in compact 128-pin plastic QFP
- PC 98/99 Compliant

### Benefits

- Worldwide support for all television standards
- WHQL certification
- Drop in replacement for the Bt878 and Bt879
- Preserves customers existing software investment in drivers and applications
- Supports the transport stream DMA for ATSC and DVB digital broadcast as well as hardware digital VCR solutions

### Applications

- Television on the PC
- PC radio
- WebTV for Windows
- DTV
- DBS
- Digital cable
- Video email, video editing and video phone
- Motion video and still frame capture
- VBI data services capture (Teletext/NABITS)

### Further Information

literature@conexant.com  
1-800-854-8099 (North America)  
33-14-906-3980 (International)  
DI.PB27 99-0358  
Personal Computing  
Printed in USA

### World Headquarters

Conexant Systems, Inc.  
4311 Jamboree Road  
P. O. Box C  
Newport Beach, CA  
92658-8902  
Phone: (949) 483-4600  
Fax: (949) 483-6375

### U.S. Florida/South America

Phone: (727) 799-8406  
Fax: (727) 799-8306

### U.S. Los Angeles

Phone: (805) 376-0559  
Fax: (805) 376-8180

### U.S. Mid-Atlantic

Phone: (215) 244-6784  
Fax: (215) 244-9292

### U.S. North Central

Phone: (630) 773-3454  
Fax: (630) 773-3907

### U.S. Northeast

Phone: (978) 692-7660  
Fax: (978) 692-8185

### U.S. Northwest/Pacific West

Phone: (408) 249-9696  
Fax: (408) 249-7113

### U.S. South Central

Phone: (972) 733-0723  
Fax: (972) 407-0639

### U.S. Southeast

Phone: (919) 858-9110  
Fax: (919) 858-8669

### U.S. Southwest

Phone: (949) 483-9119  
Fax: (949) 483-9090

### APAC Headquarters

Conexant Systems Singapore,  
Pte. Ltd.  
1 Kim Seng Promenade  
Great World City  
#09-01 East Tower  
Singapore 237994  
Phone: (65) 737 7355  
Fax: (65) 737 9077

### Australia

Phone: (61 2) 9869 4088  
Fax: (61 2) 9869 4077

### China

Phone: (86 2) 6361 2515  
Fax: (86 2) 6361 2516

### Hong Kong

Phone: (852) 2827 0181  
Fax: (852) 2827 6488

### India

Phone: (91 11) 692 4780  
Fax: (91 11) 692 4712

### Korea

Phone: (82 2) 565 2880  
Fax: (82 2) 565 1440

### Europe Headquarters

Conexant Systems France  
Les Taissounieres B1  
1681 Route des Dolines  
BP 283  
06905 Sophia Antipolis Cedex  
France  
Phone: (33 4) 93 00 33 35  
Fax: (33 4) 93 00 33 03

### Europe Central

Phone: (49 89) 829 1320  
Fax: (49 89) 834 2734

### Europe Mediterranean

Phone: (39 02) 9317 9911  
Fax: (39 02) 9317 9913

### Europe North

Phone: (44 1344) 486 444  
Fax: (44 1344) 486 555

### Europe South

Phone: (33 1) 41 44 36 50  
Fax: (33 1) 41 44 36 90

### Middle East Headquarters

Conexant Systems  
Commercial (Israel) Ltd.  
P. O. Box 12660  
Herzlia 46733, Israel  
Phone: (972 9) 952 4064  
Fax: (972 9) 951 3924

### Japan Headquarters

Conexant Systems Japan Co., Ltd.  
Shimomoto Building  
1-46-3 Hatsudai,  
Shibuya-ku, Tokyo  
151-0061 Japan  
Phone: (81 3) 5371-1567  
Fax: (81 3) 5371-1501

### Taiwan Headquarters

Conexant Systems, Taiwan Co., Ltd.  
Room 2808  
International Trade Building  
333 Keelung Road, Section 1  
Taipei 110, Taiwan, ROC  
Phone: (886 2) 2720 0282  
Fax: (886 2) 2757 6760